

# SOVET

ITALIA



# Madia Slim

collection booklet

collection  
booklet

**Slim madia**

“  
**A natural evolution that completes  
the collection. The rounded edges  
of the wooden elements perfectly  
merge with the aluminium structure.  
The different finishes of the top  
create original solutions  
and contrasts.**

Una naturale evoluzione che  
completa la collezione. Gli spigoli  
arrotondati dei moduli in legno  
si fondono perfettamente con la  
struttura in alluminio. Le varie finiture  
del piano creano inedite  
soluzioni e contrasti.

”

Through a path of material deconstruction, I have obtained essential and minimal lines able to create a versatile structure, that can be integrated in different interior spaces regardless of their styles. This is the Slim concept, a versatile and at the same time multifunctional collection thanks to the various solutions offered. From tables, coffee tables and consoles to the sofa and the upholstered benches. The collaboration with Sovet allowed me to express the project the best way possible, using the aluminum to create the Slim structure with an engineering and technological precision, thanks to the company know-how in the furnishing design. The dialogue led us to the creation of an icon of the brand, recognizable in both domestic and contract projects all over the world.

Attraverso un percorso di destrutturazione della materia sono giunto a ricavare delle linee essenziali e minimali che permettessero di creare una struttura versatile e che si integrassero negli interni al di là dello stile di questi. Questo è il concept di Slim, una collezione versatile ed allo stesso tempo multifunzione grazie alle varie soluzioni proposte. Dai tavoli, tavolini e console fino ad arrivare al divano e alle sedute. La collaborazione con Sovet mi ha permesso di esprimere al meglio il progetto, realizzando la struttura Slim in alluminio con precisione ingegneristica e tecnologica che fonda le radici nel Know-how aziendale nella progettazione d'arredo. Il dialogo ha portato alla creazione di un'icona del brand, riconoscibile in spazi abitativi e progetti in tutto il mondo.

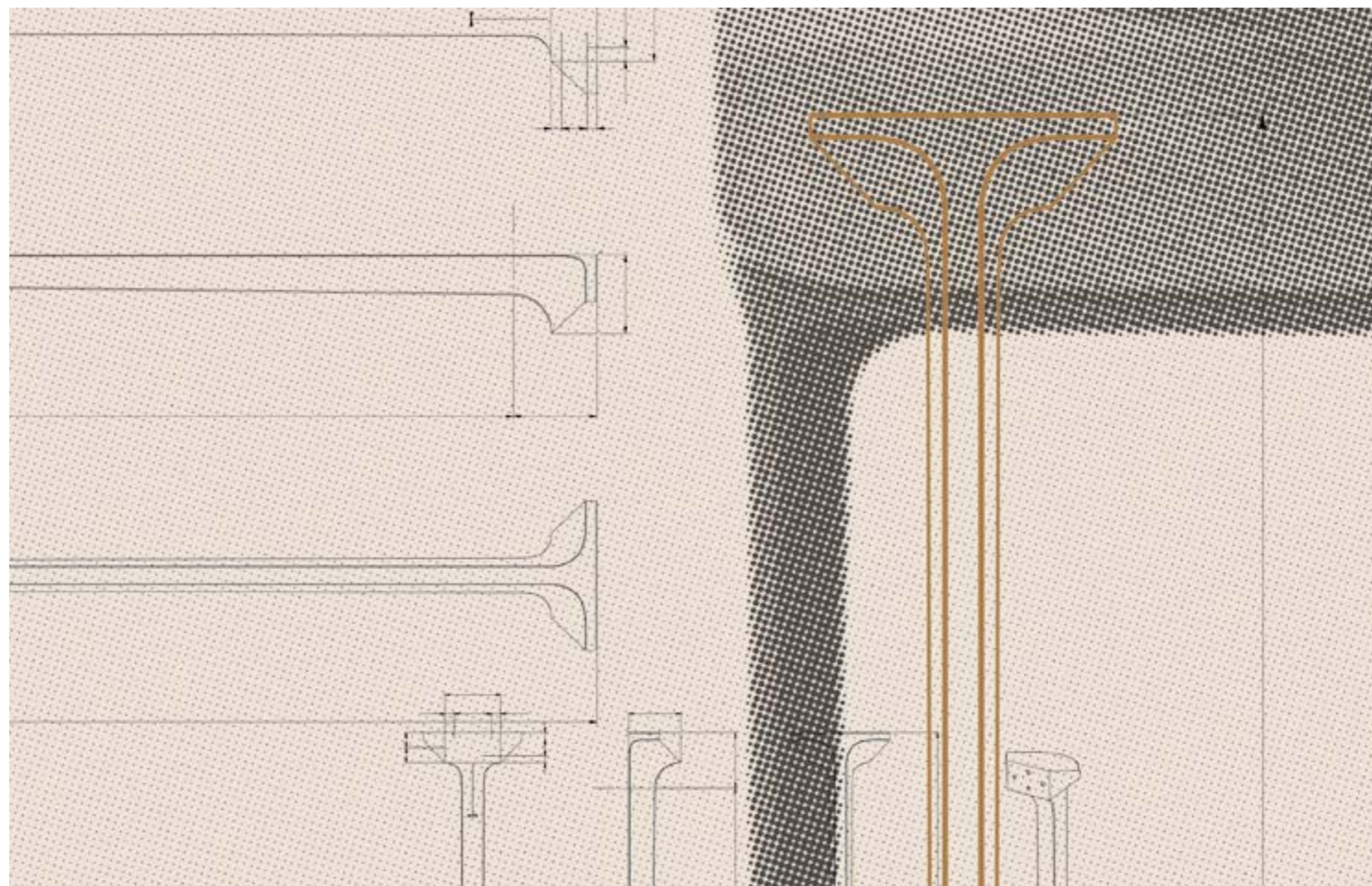



## Models & Dimensions

Sideboard with aluminium structure and legs, various finishes. Elements in mdf veneered, Canaletto walnut or oak stained wengé. Top available in different materials and finishes. Height-adjustable smoked glass internal shelf.

Madia con struttura e gambe in alluminio, varie finiture. Moduli in mdf impiallacciato Noce Canaletto o rovere tinto wengé. Piano disponibile in vari materiali e finiture. Ripiano centrale in vetro fumé regolabile in altezza.

### Slim madia h88

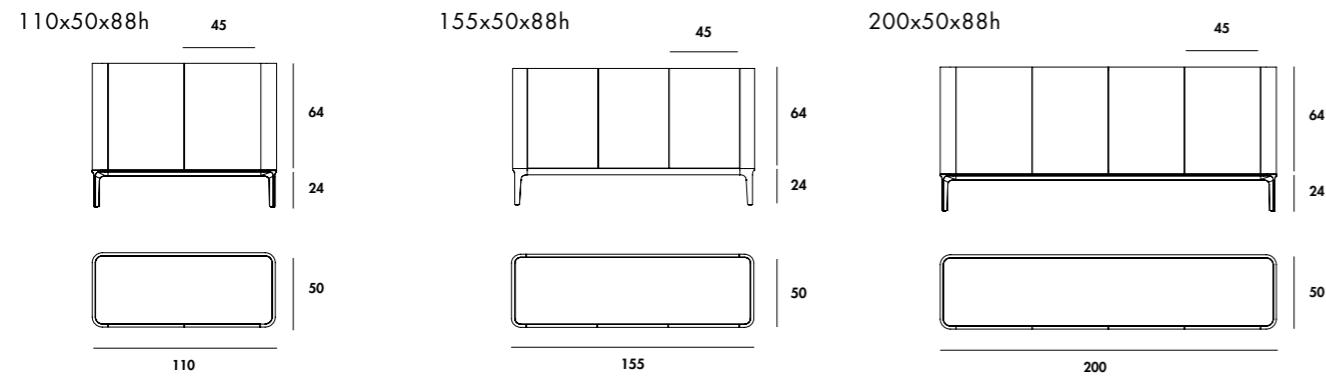

### Slim madia h101

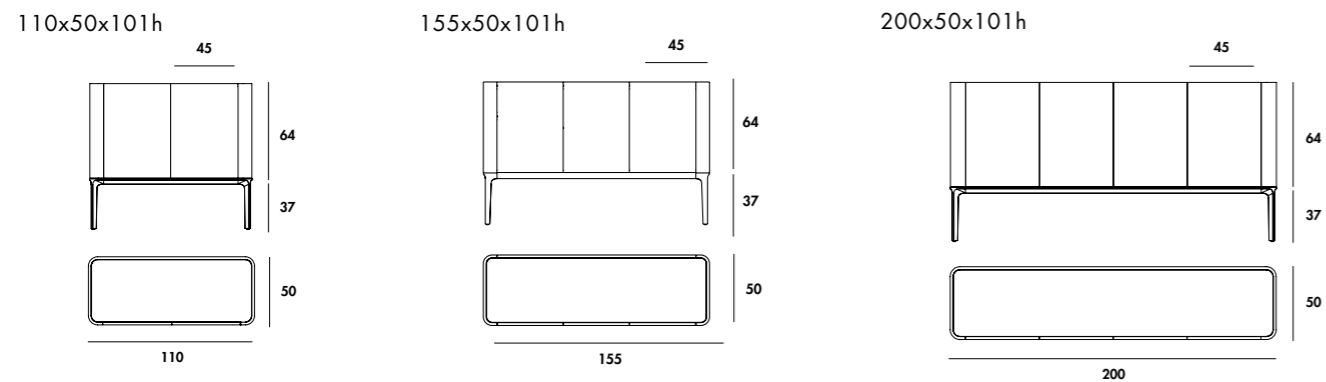

### Slim madia h110

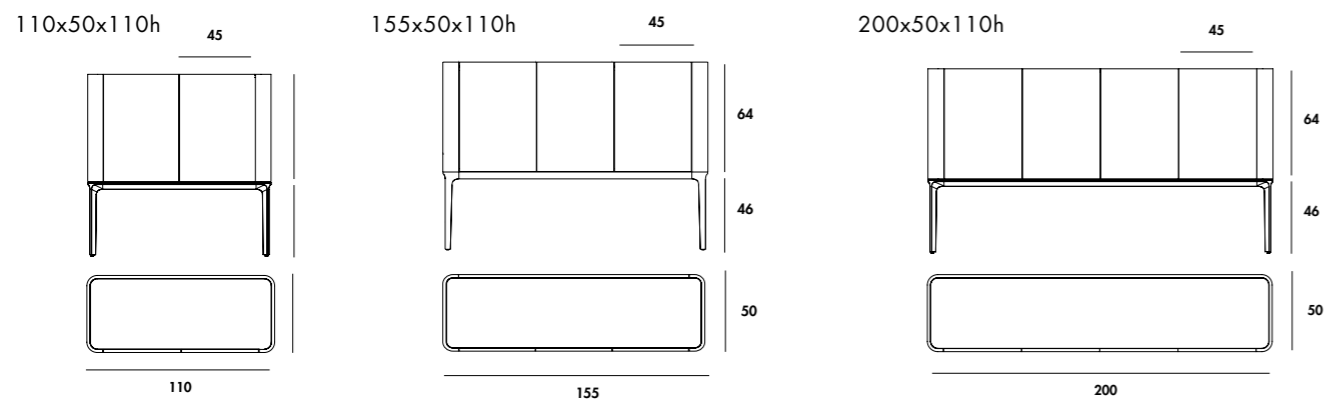

### Slim madia h138

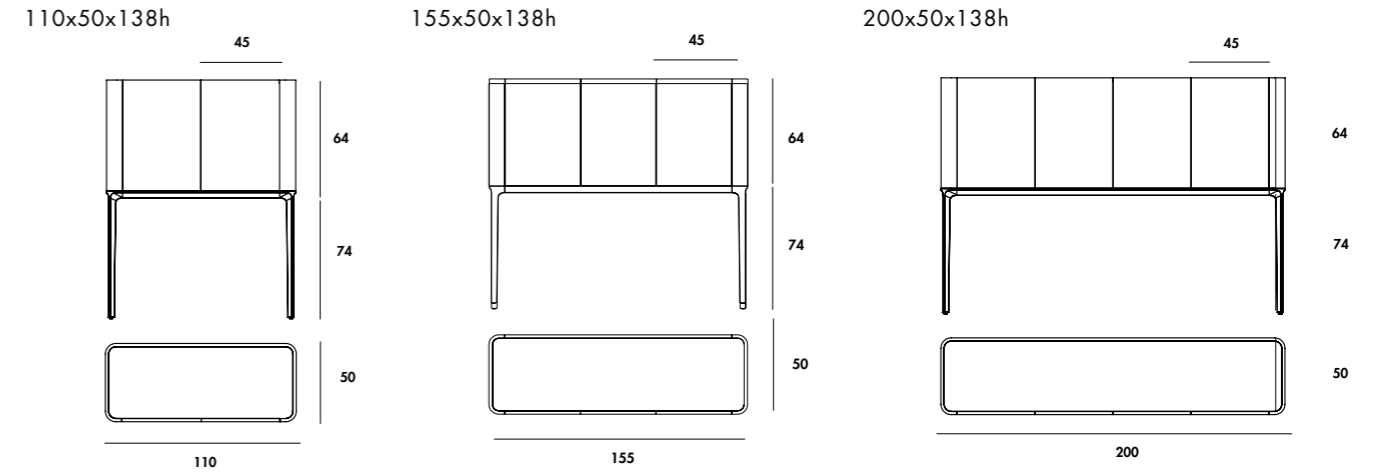

### Slim madia h152/165/174

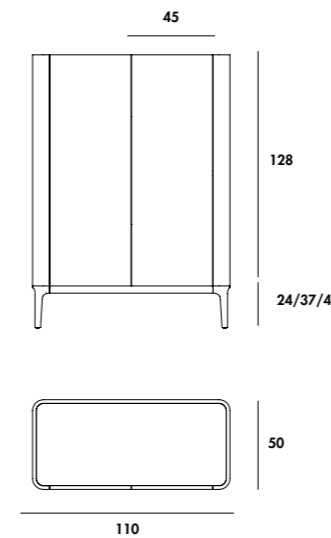

### Slim madia moon h152/165/174

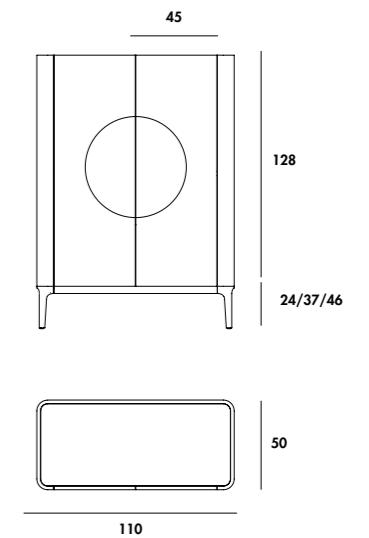

misure modulo/  
element measures

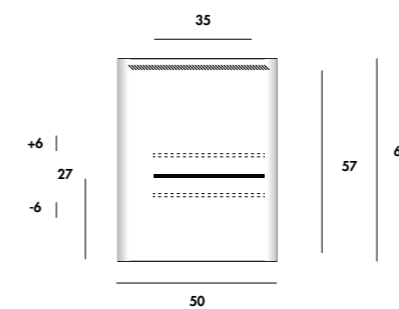

collection  
finishes



# top

## Net glass

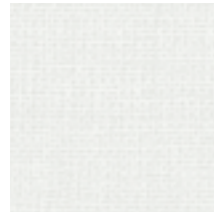

**NEB1**  
White Net glass  
Net glass bianco



**NEC1**  
Mocha Net glass  
Net glass caffè

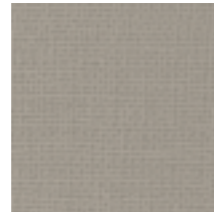

**NEC2**  
Clay Net glass  
Net glass creta



**NEC3**  
Cement Net glass  
Net glass col. cemento



**NER4**  
Rust Net glass  
Net glass col. ruggine



**NEV2**  
Moss green Net glass  
Net glass col. muschio



**NEN1**  
Black Net glass  
Net glass nero



**NEM6**  
Tobacco  
Net glass  
Net glass col.  
tabacco



**NES1**  
Champagne  
Net glass  
Net glass  
champagne



**NES1\***  
Maggese Net glass  
Net glass maggese

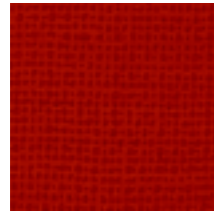

**NES1\***  
Red Net glass  
Net glass rosso

## Ceramic Ceramica Categoria CE1

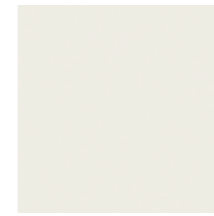

**CT**  
Ceramic titanio  
Ceramica titanio



**CJ**  
Ivory black ceramic  
Ceramica Ivory Black

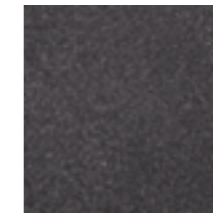

**CD**  
Dark ceramic  
Ceramica dark

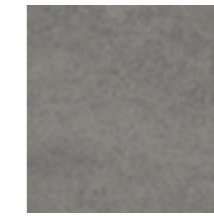

**CG**  
Grey ceramic  
Ceramica grey

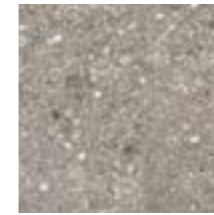

**CZ**  
Ceppo di Grè ceramic  
Ceramica Ceppo di Grè



**CC**  
Pre-polished Calacatta  
ceramic  
Ceramica Calacatta  
Prelucidata



**CX**  
Pre-polished Stone  
Grey ceramic  
Ceramica Stone Grey  
Prelucidata



**KC**  
Corten ceramic  
Ceramica Corten

**Ceramic**  
Ceramica  
Categoria CE2



**CA**  
**Arabescato light ceramic**  
Ceramica Arabescato light



**CL**  
**Polished Calacatta ceramic**  
Ceramica Calacatta lucida

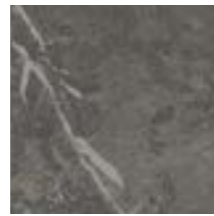

**CY**  
**Stone grey ceramic**  
Ceramica Stone grey



**CU**  
**Gaudi Stone ceramic**  
Ceramica Gaudi Stone

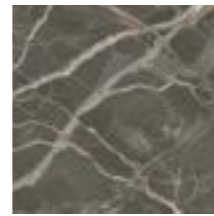

**CV**  
**Ombra di Caravaggio ceramic**  
Ceramica Ombra di Caravaggio

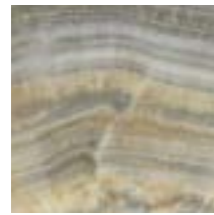

**CH**  
**Grey onyx ceramic**  
Ceramica Onice grigio

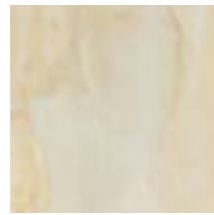

**CI**  
**Gold Onyx ceramic**  
Ceramica Onice oro

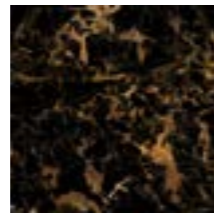

**KO**  
**Black Gold ceramic**  
Ceramica Black Gold



**CQ**  
**Polished Marquinia ceramic**  
Ceramica Marquinia lucida



**CF**  
**Eramosa ceramic**  
Ceramica Eramosa



**CW**  
**Antique ceramic**  
Ceramica Antique

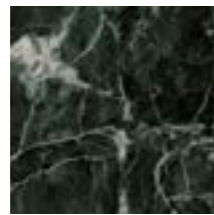

**KV**  
**Green Aver ceramic**  
Ceramica verde Aver

# Moon finishes / Finiture cerchio

**Specchio / Mirror**



**Vetro / Glass**

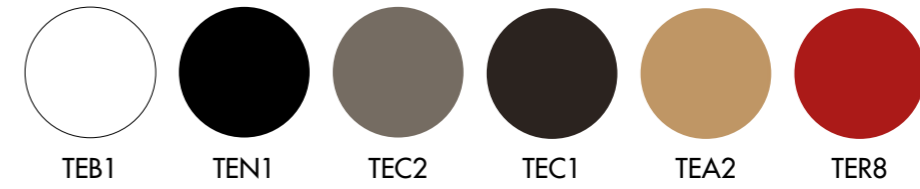

**Ceramica CE1 / CE1 Ceramic**

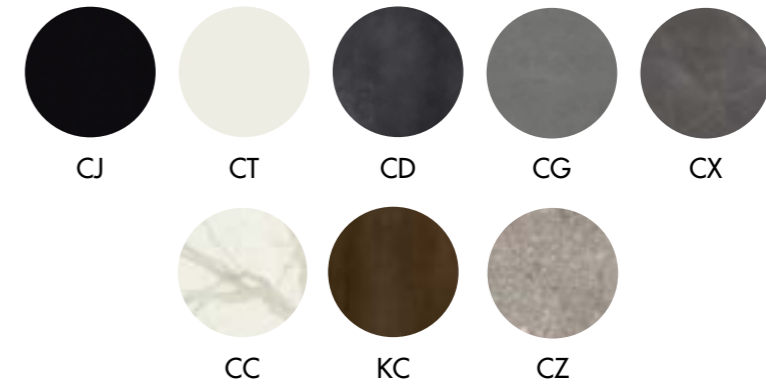

**Ceramica CE2 / CE2 Ceramic**

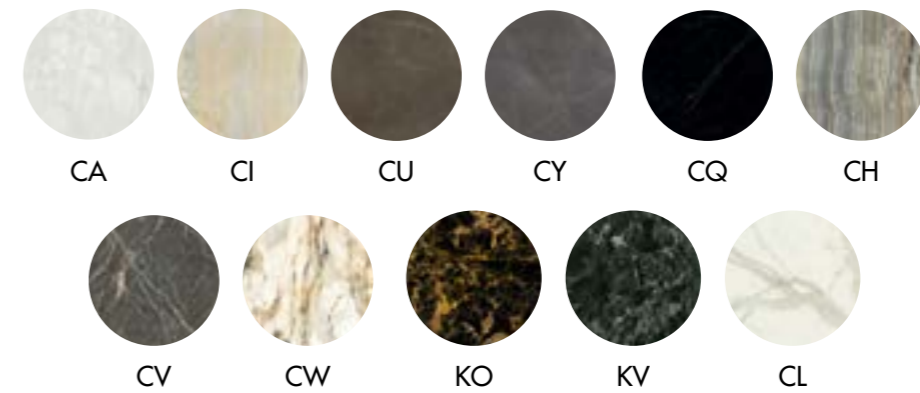

# sideboard / madia

## Wood

Legni

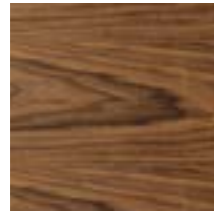

**NC**

Canaletto walnut  
Noce Canaletto



**WG**

Wengé-stained oak  
Rovere tinto wengè

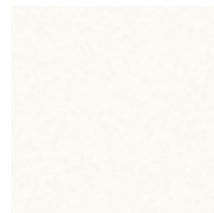

**GB \***

Embossed white  
Bianco gofrato



**GC \***

Embossed mocha  
Caffè gofrato

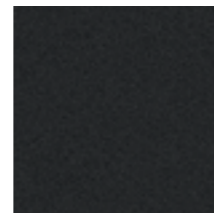

**GN \***

Embossed black  
Nero gofrato

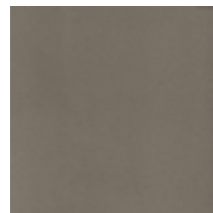

**GT \***

Embossed clay  
Creta gofrato



**GM \***

Embossed maggesi  
Maggesi gofrato



**GO \***

Embossed red  
Rosso gofrato

# legs / gambe

## Aluminium

Alluminio



**GN**

Embossed black  
Nero gofrato



**GB**

Embossed white  
Caffè gofrato



**GC**

Embossed Mocha  
Caffè gofrato



**GT**

Embossed clay  
Caffè gofrato



**BR**

Burnished aluminium  
Alluminio brunito



**GM \***

Embossed maggesi  
Maggesi gofrato



**GO \***

Embossed red  
Rosso gofrato

# structure / struttura



**GN**

Embossed black  
Nero gofrato



**GB**

Embossed white  
Caffè gofrato



**GC**

Embossed Mocha  
Caffè gofrato



**GT**

Embossed clay  
Caffè gofrato



**BR**

Burnished aluminium  
Alluminio brunito



**GM \***

Embossed maggesi  
Maggesi gofrato



**GO \***

Embossed red  
Rosso gofrato

\* Available only in Madia Slim Moon  
Disponibile solo per Madia Slim Moon



**Vetro**

Le laccature utilizzate non presentano problemi di durata: basta evitare graffi e urti contro oggetti particolarmente duri e spigolosi. Il vetro è colorato solo sulla faccia posteriore sia nei vetri laccati coprenti mono e bicolore che nei vetri acidati laccati. La tonalità dei campioni proposti è indicativa e non va pertanto intesa in senso restrittivo; può infatti differire leggermente in conformità ai margini di tolleranza riconosciuti per i materiali impiegati. I materiali impiegati possono essere puliti tranquillamente solo con acqua oppure con un detergente neutro. Evitare l'uso di abrasivi, acidi o reagenti chimici. Il vetro è interpretato attraverso la sua trasparenza, pertanto la conformità al campione può differire a seconda della superficie e degli spessori impiegati. Un esempio lampante è dato dal vetro extrachiaro che nei campioncini si presenta completamente neutro ma che nei piani di dimensioni maggiori e con spessori più consistenti assume sfumature azzurro/verdi. Per tale ragione vi preghiamo anche di segnalare con particolare attenzione articoli che debbano essere affiancati o facenti parte di una stessa commissione.

La finitura bicolore consiste nella doppia laccatura nella parte interna della lastra di vetro. La prima laccatura, visibile attraverso la trasparenza del vetro, è disponibile nelle categorie B-D. La seconda laccatura, visibile internamente, equivale al colore pastello opaco utilizzato per ottenere le finiture di cat. B. Vi facciamo presente che in questo caso l'effetto finale differisce da quello creato dalla medesima laccatura attraverso il vetro, in particolare nei colori tenui.

**Specchi**

Gli specchi oro e rosa potrebbero presentare delle piccole imperfezioni dovute alle caratteristiche tecniche del materiale. Non possono essere utilizzati in luoghi umidi. Pulire solo con panni asciutti.

**Ceramica**

I campioni riportati sono una parte delle lastre che vengono lavorate. La lastra completa si può vedere nella corrispondente cartella. Pulire utilizzando acqua e una piccola quantità di detergente neutro. Evitare l'utilizzo di detersivi contenenti cere e prodotti ceranti per evitare la formazione di strati untuosi.

**Legno**

I colori dei legni sono campioni indicativi. Pulire utilizzando un panno morbido inumidito.

**Metalli**

I colori dei metalli sono campioni indicativi. Pulire utilizzando un panno morbido inumidito.

**Tessuti/Pelli/Ecopelli/Velluti**

I colori dei tessuti sono campioni indicativi. Per la cura e la manutenzione fare riferimento alle indicazioni riportate nelle rispettive cartelle e alle schede tecniche fornite dai produttori.

Se permangono dubbi contattare l'azienda.

**Glass**

The lacquering used for our furniture is extremely durable as long as you avoid scratching it or bumping particularly hard/sharp objects against it. The glass is lacquered only on the back side both for mono or two-tones lacquered and frosted lacquered glasses. The shade of the samples is only indicative and has not to be taken as restrictive. It can in fact slightly differ in conformity to the tolerances recognized for the materials used. All the materials we use can be easily cleaned with water only or with a mild detergent. Do not use abrasive materials, acids or harsh chemicals. The glass is interpreted through its transparency, therefore the conformity to the sample might differ according to the surface and the thickness used. For example, the extralight glass is completely neutral when seen in the small samples, but it takes a light blue/greenish shade when used on bigger or thicker tops. For this reason, we beg you to indicate carefully those articles which have to be placed side by side or which are part of the same commission.

The two-tones finish consists of a double lacquering on the internal part of the glass sheet. The first lacquering, which is visible through the transparency of the glass, is available in the finishes of cat. B-D. The second lacquering, which is visible internally, is the same of the mat pastel used to get the finishes of cat. B. Please notice that the final effect is different from the one created by the same lacquering through the glass, in particular when it comes to soft colours.

**Mirrors**

Gold and rose mirrors could have small imperfections due to the particular technical characteristics of the material. We recommend not to use them in damp areas. Clean only with a dry cloth.

**Ceramic**

The shown samples are part of the bigger slabs Sovet works with. The complete slab is visible in the corresponding folder. Clean using water and a small amount of neutral detergent. Avoid using detergents with wax and waxing products to avoid the formation of greasy layers.

**Wood**

Wood colours are indicative samples. Clean using a damp soft cloth.

**Metals**

Metals colours are indicative samples. Clean using a damp soft cloth.

**Fabrics/Leathers/Fake leathers/velvets**

Fabrics colours are indicative samples. For care and maintenance please refer to the instructions present in the corresponding folders and to the technical sheets provided by the manufacturers.

In case of further doubt please get in touch with the factory.



Slim sideboard structure GN sideboard WG and CW top.



Slim sideboard structure GN sideboard WG top CH.



Slim sideboard structure GN sideboard WG top CH.





**Slim sideboard** structures GN sideboard WG and top CH.

**Slim sideboard** structures GN sideboard WG and top CO.

**In the next page**

**Slim sideboard** structures GN sideboard WG and top CO.

**Slim sofa** structures GN seat Z08.

**Slim coffee table** structures GN top CD.







**Slim sideboard** structure BR sideboard NC top CO.  
**Slim sofa** structure BR seat Z09.  
**Slim coffee table** structures GN top CD.



**Slim sideboard** structure BR sideboard NC top CO.





**Slim sideboard** structure GC sideboard NC top CO.



**Slim sideboard** structure GC sideboard NC top CO.  
**Slim table** structure GC top CO.





# sustainability is made up of facts.

Sovet has always maintained a high attention to eco-compatibility since its birth in 1987, through the selection of raw materials and the study of production processes that have the lowest impact on the environment with the aim of creating long-lasting products.

Sovet ha sempre mantenuto alta l'attenzione all'ecocompatibilità sin dalla sua nascita nel 1987, attraverso la selezione delle materie prime e lo studio di processi produttivi che abbiano il minimo impatto sull'ambiente con lo scopo di creare prodotti durevoli nel tempo.

## photovoltaic systems

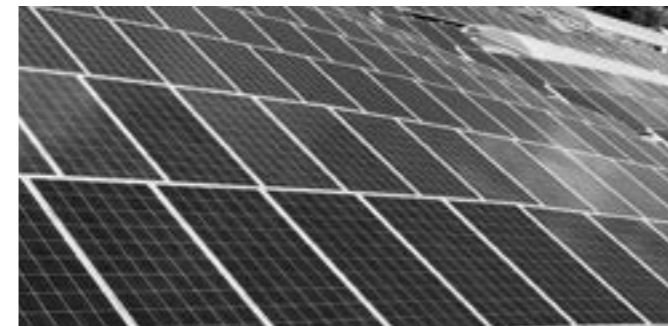

For its production processes, Sovet uses energy coming directly from renewable sources. Thanks to its photovoltaic systems, it is able to meet its own energy demand.

Per la sua produzione Sovet utilizza infatti energia derivante direttamente da fonti rinnovabili. Attraverso impianti fotovoltaici riesce a soddisfare il proprio fabbisogno energetico.



502695,549 kg emissions saved per year



2989 trees saved per year



165 barrels of oil saved per year

## packaging



Sovet uses cardboard packaging with limited presence of oil-derivates.

Sovet usa imballi di cartone costruiti ad hoc con limitata presenza di derivati del petroli.



## reducing plastic is an habits



To reduce the consumption of plastic and disposable bottles within its offices and production, Sovet created metal water bottles.

Per ridurre il consumo di plastica e bottiglie monouso all'interno dei suoi uffici e della produzione, Sovet ha creato delle borracce in metallo.

# made in italy

**The creative use of industrial processes, the use of raw materials of highest quality and the scrupulous work of master craftsmen, allow Sovet to create high quality and 100% Made in Italy collections. Thanks to state-of-the-art industrial automation systems, Sovet is also able to meet also large supply needs for contract spaces, always granting the highest quality standards. The company takes a continuous search path for materials, to create an offer of accessories that complement one another, furnishing different kinds of environments with the maximum freedom when it comes to customization.**

L'impiego creativo dei processi industriali, l'utilizzo di materie prime di assoluta qualità e le scrupolose lavorazioni eseguite da maestranze artigiane, permettono a Sovet di ottenere collezioni di alta qualità e 100% Made in Italy. Grazie a sistemi di automazione industriale all'avanguardia Sovet è in grado di soddisfare anche esigenze per grandi forniture destinate a spazi contract, sempre garantendo i più elevati standard qualitativi. Sovet intraprende un percorso di ricerca dei materiali per creare un'offerta di complementi che si integrino tra di loro, arredando varie tipologie di ambienti con la massima possibilità di personalizzazione.



